

GENERAL FEATURES:

Unidirectional wafer type knife gate valve

Connexion PN16/PN10 (DN50 - DN150), PN10 (DN200 - ...)

Monobloc body

- Designed for:
- water, liquids and gas, lightly polluted with solid material (max. 5%)
 - pneumatic transport of powders
 - paper pulp with low concentration



TESTS AND CERTIFICATES	
PED/CE	97/23/EC, Art 3.3 (SEP)
Machinery directive	DIR 2006/42/EC
Atex	Group II, categorie 3 GD
Testting procedure	EN-12266

Subject to changes

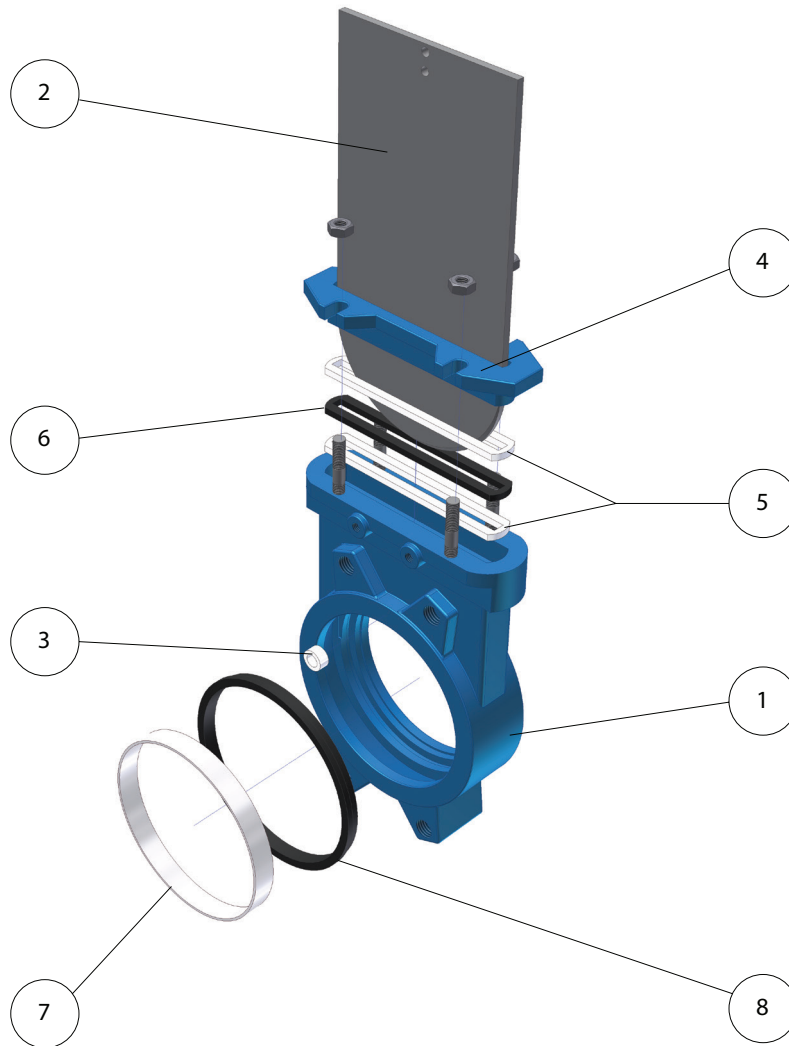

Pos.	Description	Materials	
		Version in cast iron	Version in stainless steel
1	Body	GG-25	A 351 Gr. CF8M
2	Gate	AISI 304	AISI 316
3	Guide	UHMWPE (RCH 1000)	
4	Packing gland	GJS-500	A 351 Gr. CF8M
5	Packing	RPTFE	
6	O-ring seal	EPDM	
7	Ring	AISI 316	
8	Seat	EPDM	

Kv Values

Ø	DN	Kv
2"	50	206
2 1/2"	65	305
3"	80	485
4"	100	895
5"	125	1550
6"	150	2095
8"	200	3834
10"	250	5375
12"	300	8083
14"	350	10700
16"	400	14200
18"	450	18405
20"	500	23215
24"	600	34142
28"	700	46440
32"	800	61490
36"	900	79985
40"	1000	99750

Max. differential pressure (bar)

Ø	DN	ΔP
2"	50	10
2 1/2"	65	10
3"	80	10
4"	100	10
5"	125	10
6"	150	8
8"	200	7
10"	250	5
12"	300	5
14"	350	4
16"	400	4
18"	450	3
20"	500	3
24"	600	3
28"	700	2
32"	800	2
36"	900	2
40"	1000	2

Type		Connection		Operation		Seat		Body materials		Elastomere	
A	Standard knife gate valve	1	PN 10	-	Free stem	1	Metal to metal	H	Cast iron GG-25	-	EPDM
		2	PN 6	V	Handwheel with rising stem	2	Elastomere	I	Stainles steel	/B	Buna
		3	PN 16	N	Double acting pneumatic actuator	3	Elastomere with reinforced socket	A	Carbon steel	/V	Viton
		4	PN 25	VNR	Handwheel with non-rising stem	4	Metal to metal with deflector and joint	AL	Aluminium	/S	Silicone
		5	ANSI 150	P	Lever	5	Elastomere with deflector	HH	Nodular cast iron		
		6	ANSI 300	C	Chain wheel	6	Elastomere with reinforced socket and deflector				
		7	PN 40	R	Gearbox						
				NE	Spring return pneumatic actuator, normally closed						
				NEO	Spring return pneumatic actuator, normally open						
				M	Electric actuator						
		H	Hydraulic actuator								

Special order

Example

A	1	V	2	H	/B
	PN 10	Handwheel with rising stem	Elastomere	Body in cast iron	Buna

Seat materials

Materials	Max. temperature	Applications
Metal	> 250	High temp. / Low watertight integ.
EPDM	-5 °C - 90	Non-mineral acids and oils
Nitril	-10 °C - 90	Hydrocarbons, oils and greases
Viton	-5 °C - 200	Hydrocarbons and solvents
Silicone	-30 °C - 200	Food products
PTFE	-30 °C - 250	Corrosion resistant (pH 2 up to pH 12) Leak rate: 0,5% of the tube flow

Packing materials

Materials	Max. P (bar) packing	Max. temperature (°C)	pH
Greased cotton	10	100	6 - 8
Dry cotton	0,5	100	6 - 8
Cotton + PTFE	30	120	6 - 8
Sythetic + PTFE	100	-200 / +270	0 - 14
Graphite	40	650	0 - 14
Ceramic fibre	0,3	1400	0 - 14

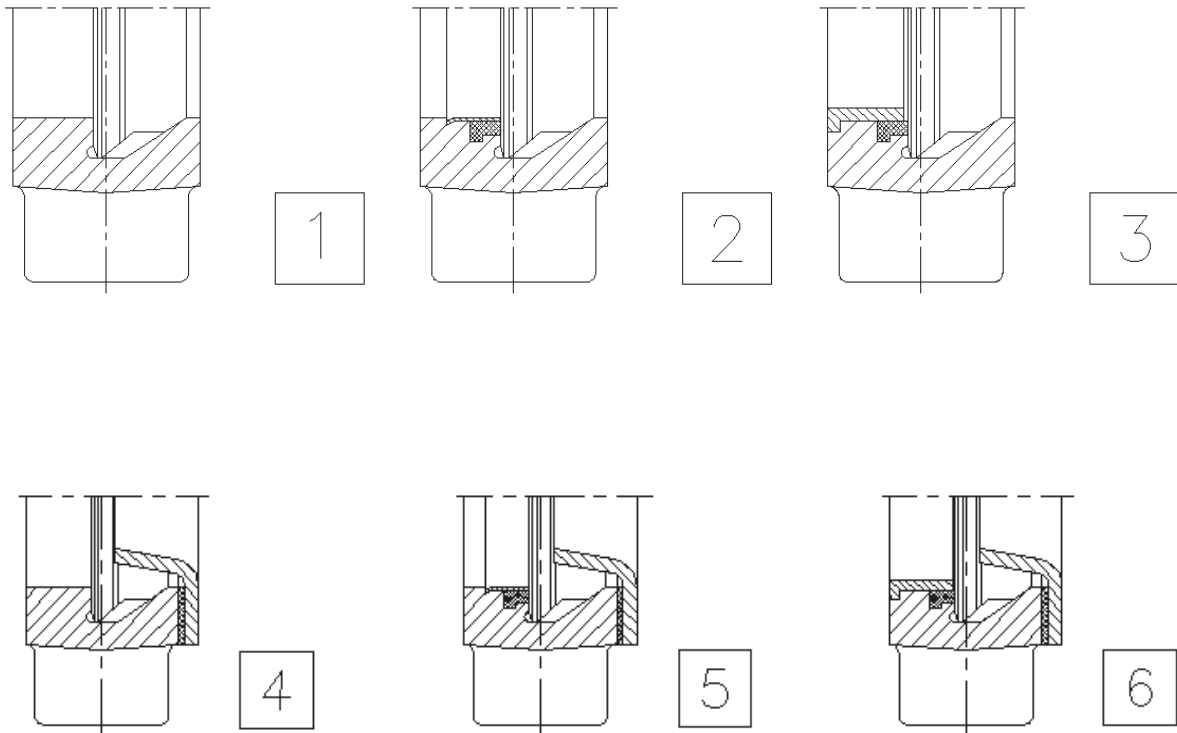

Seats

Pos.	Type	Description
1	Metal / metal seat	Without resilient seat. The estimated leakage is 1,5% of the pipe flow.
2	Standard soft seat	A resilient seat, fixed to the inside of the body via an AISI 316 stainless steel retaining ring.
3	Soft seat with reinforced socket	A resilient seat with reinforced socket, fixed to the inside of the body via an AISI 316 stainless steel retaining ring. This protects the valve from abrasion and cleans the gate when operated,
4	Metal / metal seat with deflector	Same as 1, but including a deflector. (A cone shaped ring which protects the valve from abrasion and guides the flow to the centre of the valve.)
5	Standard soft seat with deflector	Same as 2, but including a deflector. (A cone shaped ring which protects the valve from abrasion and guides the flow to the centre of the valve.)
6	Soft seat with reinforced socket with deflector	Same as 3, but including a deflector. (A cone shaped ring which protects the valve from abrasion and guides the flow to the centre of the valve.)

MATERIALS:

-Handwheel in nodular iron

OPTIONS:

- Locking devices
- Extensions: stand, pipe, plates
- DN higher than those given in the table

INCLUDING:

- Handwheel
- Stem
- Nut
- Stem protection hood

REMARKS:

-From DN 600, the actuator is with gears

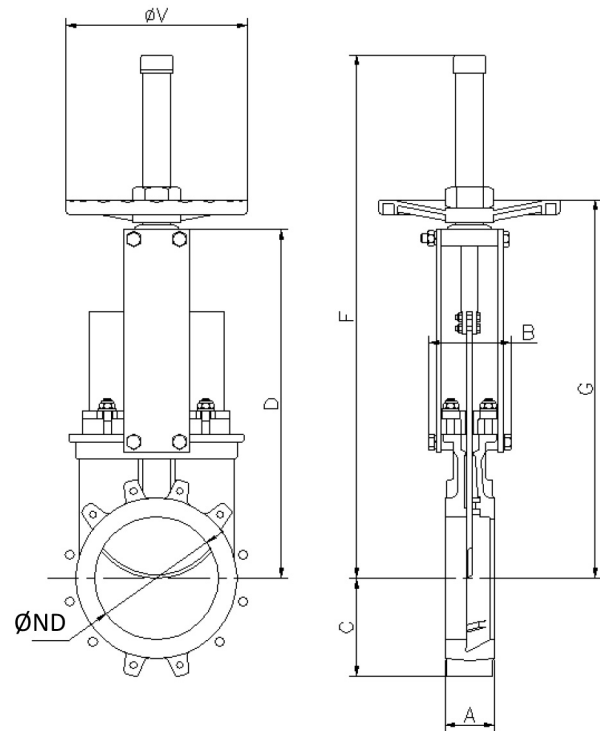
Dimensions (in mm)

Ø	DN	A	B	C	D	F	G	ØV	Kg
2"	50	40	91	61	241	410	280	225	7
2 1/2"	65	40	91	68	268	437	308	225	8
3"	80	50	91	91	294	463	333	225	9
4"	100	50	91	104	334	503	373	225	11
5"	125	50	101	118	367	586	407	225	13
6"	150	60	101	130	419	638	458	225	17
8"	200	60	118	159	525	816	578	325	28
10"	250	70	118	196	626	1017	679	325	40
12"	300	70	118	230	726	1117	779	380	56
14"	350	96	290	254	797	1337	906	450	94
16"	400	100	290	287	903	1443	1012	450	116
18"	450	106	290	304	989	1629	1098	450	162
20"	500	110	290	340	1101	1741	1210	450	191
24"	600	110	290	398	1307	2047	1416	450	264
28"	700	110	320	453	1506	-	-	-	441
32"	800	110	320	503	1720	-	-	-	568
36"	900	110	320	583	1953	-	-	-	736
40"	1000	110	320	613	2137	-	-	-	921

MATERIALS:

-Handwheel in nodular iron

OPTIONS:

- Square nut
- Locking devices
- Extensions: stand, pipe, plates
- DN higher than those given in the table

INCLUDING:

- Handwheel
- Stem
- Nut
- Guide bearings on the yoke

REMARKS:

-From DN 600, the actuator is with gears

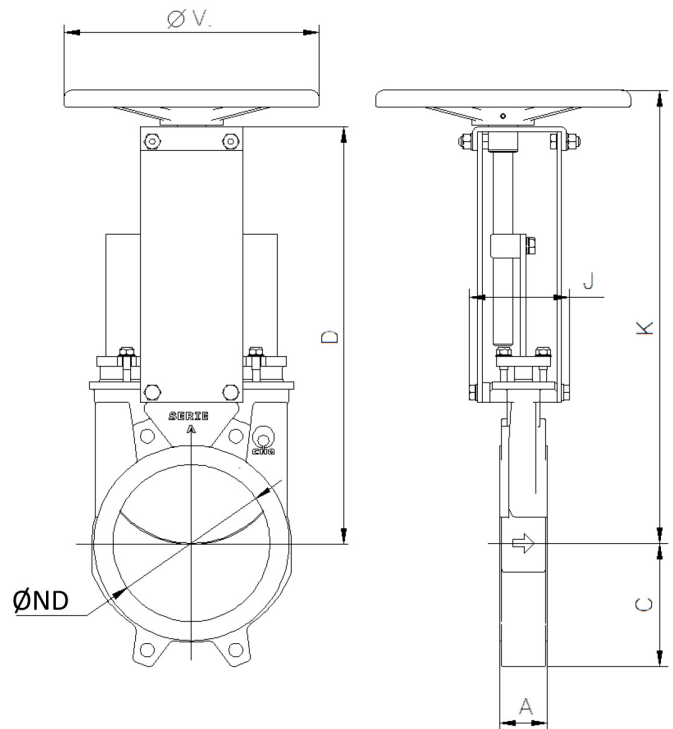
Dimensions (in mm)

Ø	DN	A	C	D	J	K	ØV	Kg
2"	50	40	61	241	101	280	225	7
2 1/2"	65	40	68	268	101	308	225	8
3"	80	50	91	294	101	333	225	9
4"	100	50	104	334	101	373	225	11
5"	125	50	118	367	111	407	225	13
6"	150	60	130	419	111	458	225	17
8"	200	60	159	525	128	578	325	29
10"	250	70	196	626	128	679	325	40
12"	300	70	230	726	128	779	380	53
14"	350	96	254	797	305	906	450	93
16"	400	100	287	903	305	1012	450	126
18"	450	106	304	989	305	1098	450	160
20"	500	110	340	1101	305	1210	450	193
24"	600	110	398	1307	305	1416	450	264
28"	700	110	453	1506	335	-	-	435
32"	800	110	503	1720	335	-	-	580
36"	900	110	583	1953	335	-	-	740
40"	1000	110	613	2137	335	-	-	925

MATERIALS:

-Wheel in nodular iron

OPTIONS:

- Locking devices
- Extensions: stand, pipe, plates
- Non-rising stem
- DN higher than those given in the table

INCLUDING:

- Handwheel
- Stem
- Nut
- Hood

REMARKS:

-From DN 600, the actuator is with gears (see * in table)

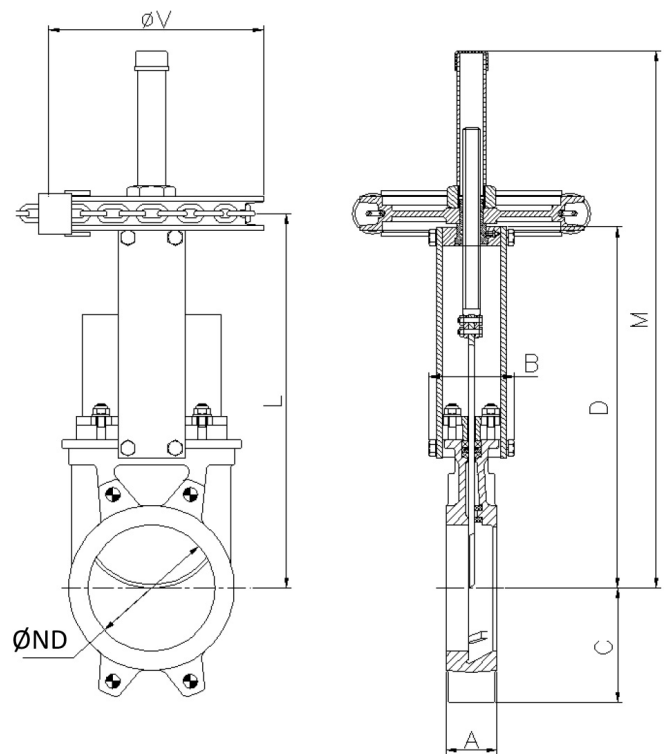
Dimensions (in mm)

Ø	DN	A	B	C	D	L	M	ØV	Kg
2"	50	40	91	61	241	280	410	225	7
2 1/2"	65	40	91	68	268	308	437	225	8
3"	80	50	91	91	294	333	463	225	9
4"	100	50	91	104	334	373	503	225	11
5"	125	50	101	118	367	407	586	225	13
6"	150	60	101	130	419	458	638	225	17
8"	200	60	118	159	525	578	816	300	29
10"	250	70	118	196	626	679	1017	300	40
12"	300	70	118	230	726	779	1117	300	53
14"	350	96	290	254	797	906	1337	402	93
16"	400	100	290	287	903	1012	1443	402	126
18"	450	106	290	304	989	1098	1629	402	160
20"	500	110	290	340	1101	1210	1741	402	193
24"	600	110	290	398	1307	1416	2047	402	264
28"	700	110	320	453	1506	1658	2406	402*	435
32"	800	110	320	503	1720	1905	2790	402*	580
36"	900	110	320	583	1953	2115	3130	402*	740
40"	1000	110	320	613	2137	2310	3440	402*	925

OPTIONS:

- Chainwheel
- Locking devices
- Extensions: stand, pipe, plates
- Non-rising stem

INCLUDING:

- Stem
- Yoke
- Cone shaped gearbox
- Handwheel

REMARKS:

- Standard ratio = 4:1
- Gearbox can be mounted frontally (standard) or laterally (optional)

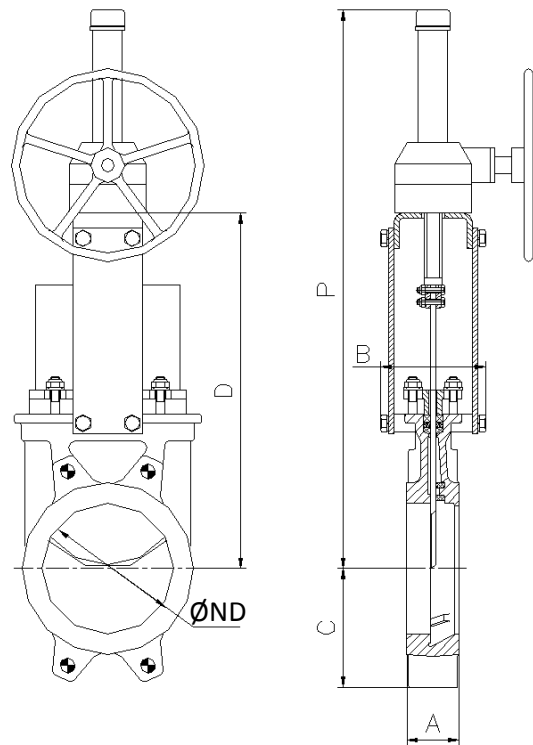
Dimensions (in mm)

Ø	DN	A	B	C	D	P	Kg
2"	50	40	91	61	241	540	17
2 1/2"	65	40	91	68	268	566	18
3"	80	50	91	91	294	592	19
4"	100	50	91	104	334	632	20
5"	125	50	101	118	367	665	24
6"	150	60	101	130	419	717	26
8"	200	60	118	159	525	942	50
10"	250	70	118	196	626	1043	63
12"	300	70	118	230	726	1194	77
14"	350	96	290	254	797	1335	106
16"	400	100	290	287	903	1441	134
18"	450	106	290	304	989	1677	173
20"	500	110	290	340	1101	1789	216
24"	600	110	290	398	1307	2045	284
28"	700	110	320	453	1506	2401	430
32"	800	110	320	503	1720	2715	615
36"	900	110	320	583	1953	3034	768
40"	1000	110	320	613	2137	3351	972

INCLUDING:

- Lever
- Rod
- Guide bearing
- External limiting switches to maintain the position

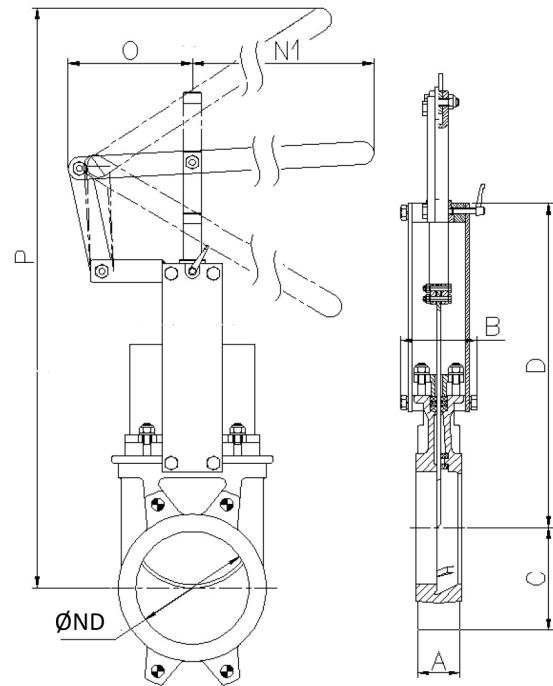
Dimensions (in mm)

Ø	DN	A	B	C	D	N1	O	P	Kg
2"	50	40	91	61	241	325	155	504	8
2 1/2"	65	40	91	68	268	325	155	526	9
3"	80	50	91	91	294	325	155	549	10
4"	100	50	91	104	334	325	155	605	11
5"	125	50	101	118	367	425	155	902	14
6"	150	60	101	130	419	425	155	956	16
8"	200	60	118	159	525	620	290	1027	32
10"	250	70	118	196	626	620	290	1416	54
12"	300	70	118	230	726	620	290	1525	57

MATERIALS:

- Aluminium jacket
- Covers in nodular iron or carbon steel
- Rod in AISI 304
- Piston in rubber coated steel
- O-rings in Nitrile
- Spring in steel

REMARKS:

- Working pressure between 6 and 10 kg/cm².
- Available with spring opening or closing in case of failure.
- Spring activated for valves with diameters up to DN 300. Larger diameters require a double acting actuator.

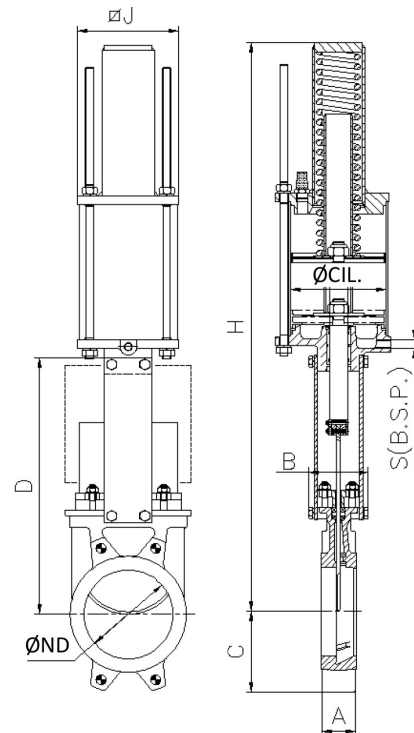

Dimensions (in mm)

Ø	DN	A	B	C	D	ØCIL	ØJ	S (B.S.P.)	H	Kg
2"	50	40	91	61	241	125	135	1/4"	781	19
2 1/2"	65	40	91	68	268	125	135	1/4"	806	22
3"	80	50	91	91	294	125	135	1/4"	833	23
4"	100	50	91	104	334	125	135	1/4"	873	24
5"	125	50	101	118	367	160	170	1/4"	909	35
6"	150	60	101	130	419	160	170	1/4"	960	36
8"	200	60	118	159	525	200	215	3/8"	1355	66
10"	250	70	118	196	626	250	270	3/8"	1844	130
12"	300	70	118	230	726	250	270	3/8"	2005	143

MATERIALS:

- Aluminium jacket
- Covers in Aluminium (DN 50 - DN 200)
- Covers in nodular iron or carbon steel (> DN 200)
- Rod in AISI 304
- Piston in rubber coated steel
- O-rings in Nitrile

REMARKS:

- Working pressure between 6 and 10 kg/cm².
- On request, the actuator can be made entirely of stainless steel.

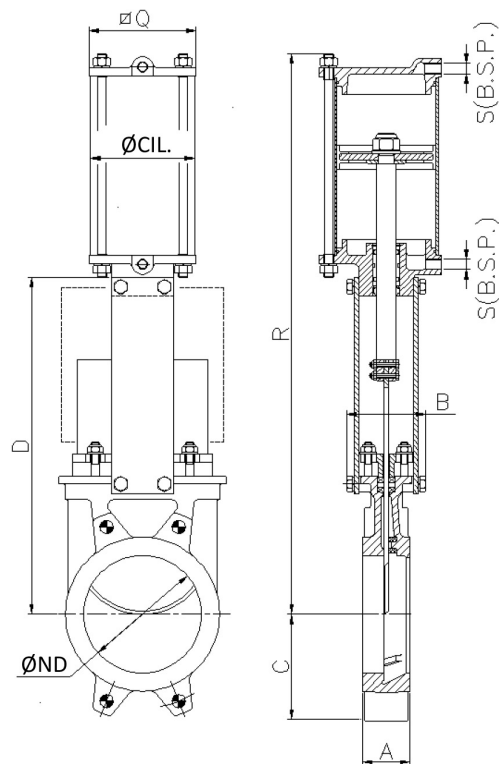

Dimensions (in mm)

Ø	DN	A	B	C	D	ØCIL	ØQ	S (B.S.P.)	R	Kg
2"	50	40	91	61	241	80	96	1/4"	416	7
2 1/2"	65	40	91	68	268	80	96	1/4"	456	8
3"	80	50	91	91	294	80	96	1/4"	498	9
4"	100	50	91	104	334	100	115	1/4"	562	12
5"	125	50	101	118	367	125	138	1/4"	636	18
6"	150	60	101	130	419	125	138	1/4"	717	22
8"	200	60	118	159	525	160	175	1/4"	874	37
10"	250	70	118	196	626	200	218	3/8"	1036	58
12"	300	70	118	230	726	200	218	3/8"	1182	72
14"	350	96	290	254	797	250	270	3/8"	1381	130
16"	400	100	290	287	903	250	270	3/8"	1530	155
18"	450	106	290	304	989	300	382	1/2"	1676	225
20"	500	110	290	340	1101	300	382	1/2"	1839	257
24"	600	110	290	398	1307	300	382	1/2"	2146	340
28"	700	110	320	453	1506	350	426	1/2"	2481	556
32"	800	110	320	503	1720	350	426	1/2"	2798	679
36"	900	110	320	583	1953	400	508	1/2"	3167	840
40"	1000	110	320	613	2137	400	508	1/2"	3451	1053

INCLUDING:

- Hydraulic cylinder
- Mounting flange

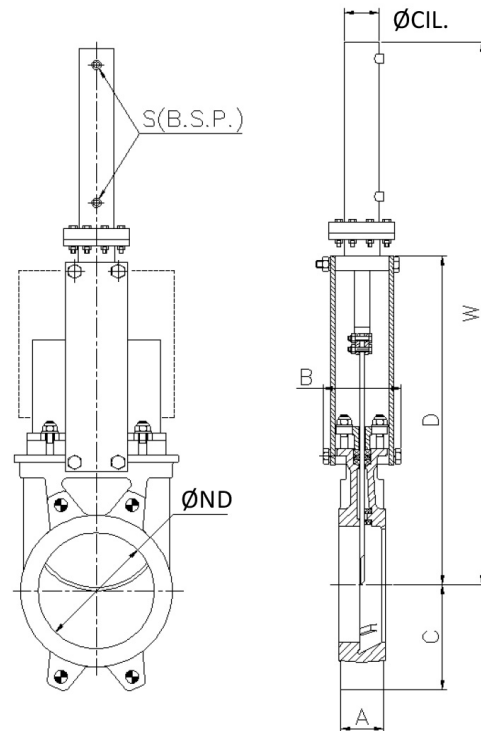

Dimensions (in mm)

Ø	DN	A	B	C	D	W	ØCIL	S (B.S.P.)	Kg
2"	50	40	91	61	241	457	25	3/8"	7
2 1/2"	65	40	91	68	268	500	25	3/8"	8
3"	80	50	91	91	294	560	25	3/8"	9
4"	100	50	91	104	334	620	32	3/8"	12
5"	125	50	101	118	367	683	32	3/8"	15
6"	150	60	101	130	419	755	40	3/8"	20
8"	200	60	118	159	525	926	50	3/8"	31
10"	250	70	118	196	626	1077	50	3/8"	44
12"	300	70	118	230	726	1246	50	3/8"	62
14"	350	96	290	254	797	1376	50	3/8"	100
16"	400	100	290	287	903	1532	63	3/8"	138
18"	450	106	290	304	989	1707	63	3/8"	161
20"	500	110	290	340	1101	1869	63	3/8"	223
24"	600	110	290	398	1307	2176	80	3/8"	325
28"	700	110	320	453	1506	2525	80	1/2"	481
32"	800	110	320	503	1720	2839	100	1/2"	678
36"	900	110	320	583	1953	3172	100	1/2"	861
40"	1000	110	320	613	2137	3496	125	1/2"	1103

Connection DIN

Ø	DN	●	○	Metric	T	ØK
2"	50	4	-	M16	10	125
2 1/2"	65	4	-	M16	10	145
3"	80	4	4	M16	12	160
4"	100	4	4	M16	12	180
5"	125	4	4	M16	12	210
6"	150	4	4	M 20	17	240
8"	200	4	4	M 20	16	295
10"	250	6	6	M 20	19	350
12"	300	6	6	M 20	19	400
14"	350	10	6	M 20	28	460
16"	400	10	6	M 24	28	515
18"	450	14	6	M 24	28	565
20"	500	14	6	M 24	34	620
24"	600	14	6	M 27	26	725
28"	700	16	8	M 27	25	840
32"	800	16	8	M 30	22	950
36"	900	20	8	M 30	21	1050
40"	1000	20	8	M 33	21	1160

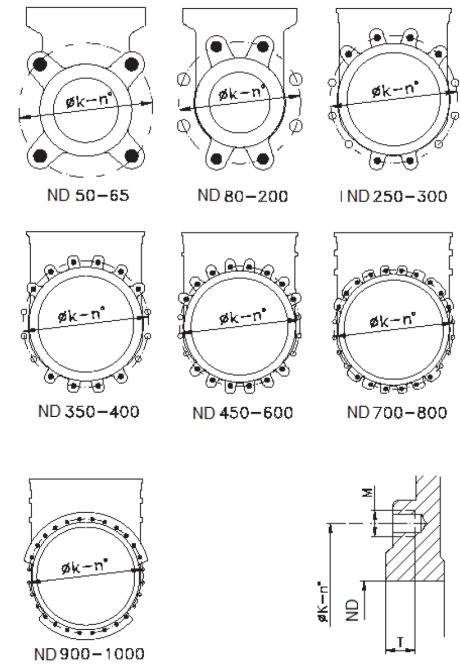
- Blind tapped holes
- Through holes



Connection ANSI

Ø	●	○	R UNC	T	ØK
2"	4	-	5/8"	10	120,6
2 1/2"	4	-	5/8"	10	139,7
3"	4	-	5/8"	12	152,4
4"	4	4	5/8"	12	190,5
5"	4	4	3/4"	12	215,9
6"	4	4	3/4"	17	241,3
8"	4	4	3/4"	16	298,4
10"	6	6	7/8"	19	361,9
12"	6	6	7/8"	19	431,8
14"	8	4	1"	28	476,2
16"	10	6	1"	28	539,7
18"	10	6	1 1/8"	28	577,8
20"	14	6	1 1/8"	34	635
24"	14	6	1 1/4"	26	749,3
28"	20	8	1 1/4"	25	863,6
30"	20	8	1 1/4"	22	914,4
32"	18	10	1 1/2"	21	977,9
36"	20	12	1 1/2"	21	1085,9
40"	24	12	1 1/2"	30	1200,2

- Blind tapped holes
- Through holes

